



# Supplier Packaging Requirements for Production Parts

# INDEX

## PAGE

|    |  |    |
|----|--|----|
| 1  | INTRODUCTION                               | 4  |
| 2  | GOALS                                      | 5  |
| 3  | DEVELOPMENT PROCESS AND APPROVAL           | 5  |
|    | 3.1 Wabash National Responsibilities       | 5  |
|    | 3.2 Suppliers Responsibilities             | 5  |
| 4  | PACKAGING GUIDELINES for PRODUCTION PARTS  | 6  |
| 5  | GUIDELINES                                 | 7  |
|    | 5.1 Pricing                                | 7  |
| 6  | DESIGN                                     | 7  |
|    | 6.1 Expendable packaging                   | 7  |
|    | 6.2 Returnable packaging                   | 8  |
| 7  | PACKAGING AGREEMENT SUBMISSION             | 8  |
| 8  | PROBLEM REPORTING / RESOLUTION (PR/R)      | 8  |
| 9  | CHOOSING THE RIGHT CONTAINER               | 9  |
| 10 | DECISION PROCESS for CONTAINER RIGHTSIZING | 10 |
| 11 | ERGONOMIC GUIDELINES                       | 11 |
|    | 11.1 Container Size and Weight             | 11 |
| 12 | SOME RECOMMENDED HANDHOLDS and DIMESIONS   | 12 |
| 13 | TESTING AND VALIDATION                     | 12 |
|    | 13.1 Package Testing                       | 12 |
|    | 13.2 Supplier Responsibilities             | 13 |
| 14 | HAZARDOUS MATERIALS                        | 13 |
| 15 | RETURNABLE CONTAINER SYSTEMS               | 14 |
| 16 | MAINTENANCE, REPAIR AND CLEANING           | 14 |
|    | 16.1 Wabash National Responsibilities      | 14 |
|    | 16.2 Supplier Responsibilities             | 14 |
| 17 | RETURNABLE PACKAGING OWNERSHIP             | 15 |
|    | 17.1 Wabash National Responsibilities      | 15 |
|    | 17.2 Supplier Responsibilities             | 16 |
| 18 | EXPENDABLE CONTAINER SYSTEMS               | 16 |
|    | 18.1 Pallet Size and Construction          | 16 |
|    | 18.1.1 Size                                | 16 |
|    | 18.1.2 North American Standards            | 17 |
|    | 18.1.3 Metric Standards                    | 17 |
|    | 18.1.4 Construction                        | 17 |
|    | 18.2 Corrugated Pallets                    | 18 |
| 19 | CONTAINER SIZE AND CONSTRUCTION            | 19 |
| 20 | CONTAINER CLOSURE                          | 21 |
| 21 | CONTAINER SECUREMENT                       | 21 |
|    | 21.1 Unitizing Adhesives                   | 22 |
|    | 21.2 Plastic (Non-Metallic) Strapping      | 22 |
|    | 21.3 Stretch film                          | 22 |
| 22 | SYSTEM PERFORMANCE CHARACTERISTICS         | 22 |

|    |   |    |
|----|---|----|
| 23 | EXPORT / IMPORT REQUIREMENTS                    | 23 |
| 24 | INTERNAL DUNNAGE                                | 24 |
| 25 | SHIPPING LABELS                                 | 24 |
| 26 | PACKAGING EXAMPLES                              | 25 |
| 27 | RECYCLING INFORMATION                           | 27 |
| 28 | WASTEFUL, EXCESSIVE, OR NON-RECYCLABLE MATERIAL | 28 |
| 29 | FORMS AND SUPPLEMENT GUIDELINES                 | 29 |
| 30 | FORMS AND SUPPLEMENT GUIDELINES                 | 30 |
|    | 30.1 Attachment A1                              | 31 |
|    | 30.2 Attachment A2                              | 32 |
|    | 30.3 Attachment B                               | 33 |
|    | GLOSSARY  | 34 |
|    | WABASH / SUPPLIER CHECKLIST                     | 37 |

Remaining Page Intentionally Left Blank

# 1 INTRODUCTION

This specification manual is intended for use by all of Wabash National suppliers for the development of part containerization which maintains optimum part quality while complying with lean material flow strategies in support of Wabash National.

The following are basic requirements that a supplier must adhere to in developing all containerization. These requirements may be altered / modified by supplemental requirements by Wabash National. *The use of these guidelines no way relieves the supplier of responsibility for part quality.* These guidelines should apply to all production parts prior to quote submission. Any deviations or alterations must be approved in writing by Wabash National.

## **2 GOALS**

- 2.1 All parts are received in superior quality.
- 2.2 Parts are presented with operator ergonomics and work cell efficiency considered.
- 2.3 Achieve maximum pack density while minimizing costs.
- 2.4 Provide responsible final disposition of obsolete packaging materials by maximizing the use of recyclable materials to minimize disposal of Dunnage.

## **3 DEVELOPMENT PROCESS AND APPROVAL**

- 3.1 Wabash National Responsibilities:
  - 3.1.1 Recommend containerization based on the manufacturing facilities requirements.
  - 3.1.2 Approve the containerization plan.
  - 3.1.3 Assist the supplier with the containerization plan as required.
  - 3.1.4 Determine system size, quantity, and allocation of returnable containers.
- 3.2 Supplier Responsibilities
  - 3.2.1 Review document(s) to ensure all guidelines are understood and met.
  - 3.2.2 Discuss with Wabash National any specific requirements for receiving material / parts at the manufacturing facility.
  - 3.2.3 Ensure the pack validation can be completed within / before the program start-up date.
  - 3.2.4 Returnable packaging designed, owned, and provided by the supplier must be approved by Wabash National prior to shipments ship dates.

- 3.2.5 The supplier name and the container identification must be clearly visible on each container.

#### **4 PACKAGING GUIDELINES for PRODUCTION PARTS**

- 4.1 A completed Supplier Packaging Information Form to Wabash National with all part quote submissions (Attachment B).
- 4.2 Provide a sample production container, with parts, for approval when requested.
- 4.3 Design a back up expendable system when a returnable system is used (of same size returnable footprint, and equal to returnable standard pack quantity) which may be required for: premium shipments, production run ahead programs, returnable container outages, etc.
- 4.4 Plan and maintain sufficient supply of suitable expendable packaging. Alternate pricing for expendable packaging costs must be prearranged with Wabash National.
- 4.5 Agree to all supplier responsibilities as outlined in this manual / guidelines.

## 5 GUIDELINES

### 5.1 Pricing

- 5.1.1 Packaging costs must be included in all part quotations and clearly defined in the piece price.
- 5.1.2 All pricing must be negotiated with Wabash National. Returnable systems must be cost justified considering system size requirements, freight, housekeeping and lean material handling / processing costs.
- 5.1.3 No price increases will be granted to correct defective and / or non-conforming packaging.

## 6 DESIGN

### 6.1 Expendable packaging

- 6.1.1 Right-sized expendable packaging is considered mainstream. Specifications and drawings for each of the acceptable Wabash National right sized expendable cartons are available upon written request. Suppliers are responsible for designing their own expendable packaging. This includes the expendable packaging for the primary container, expendable dunnage used within expendable and returnable containers, and expendable back-up packaging for returnable container systems.
- 6.1.2 Suppliers can receive assistance from the packaging suppliers and, or request, assistance from Wabash National. This does not relieve them of their responsibility to provide a quality part.

## 6.2 Returnable packaging:

6.2.1 When a returnable container is required by Wabash National, suppliers are responsible to provide a design that meets all Wabash National requirements, while ensuring part integrity during shipment.

6.2.2 For specialized design requirements, Wabash National may choose to assume responsibility for the packaging design.

## 7 PACKAGING AGREEMENT SUBMISSION

7.1 For all quotations, suppliers must submit a Supplier Packaging Information (Attachment B) form for each part.

7.2 Changes to part number, quantities, packaging materials or dimensions require a re-submittal of the Supplier Packaging Information form.

7.3 All exceptions or requests for deviations, to these packaging requirements must be approved by Wabash National.

## 8 PROBLEM REPORTING / RESOLUTION (PR/R)

The Problem Reporting / Resolution (PR/R) system is a common process at Wabash National, to report and resolve problems between customers and suppliers. The process is closed loop, beginning when the originating plant notifies the supplier and the sourcing unit that non-conforming material or packaging has been received. The process then mandates that the supplier responds with a problem resolution plan, root cause determination, corrective action, implementation process and implementation dates. The PR/R process closes when the originator verifies the supplier's response.

## 9 CHOOSING THE RIGHT CONTAINER

- 9.1 If a specific container requirement has not been indicated in the request for quote, use the Decision Process for Container Rightsizing to select the container. This rightsizing model along with the Standard Container Listing (See Attachments A1 & A2) ensures the best right sized container is chosen to optimize the entire material flow process from supplier through user. **All Containers shipped to Wabash National manufacturing facilities must be chosen from the Wabash National Standard Container Listing.** The Standard Container Listing represents the required container sizes, both for expendable and returnable cartons/containers, approved by Wabash National. However, when product dimensions dictate, an alternate container size will be permitted. Exceptions to the Standard Container Listing must be pre-approved by Wabash National in advance. Contact Wabash National for assistance.
- 9.2 Suppliers must document the selected container plan by completing the Wabash National Supplier Packaging Information Form (See Attachment B). This form, with complete instructions can be sent to the supplier upon written request to Wabash National.

# 10 DECISION PROCESS for CONTAINER RIGHTSIZING

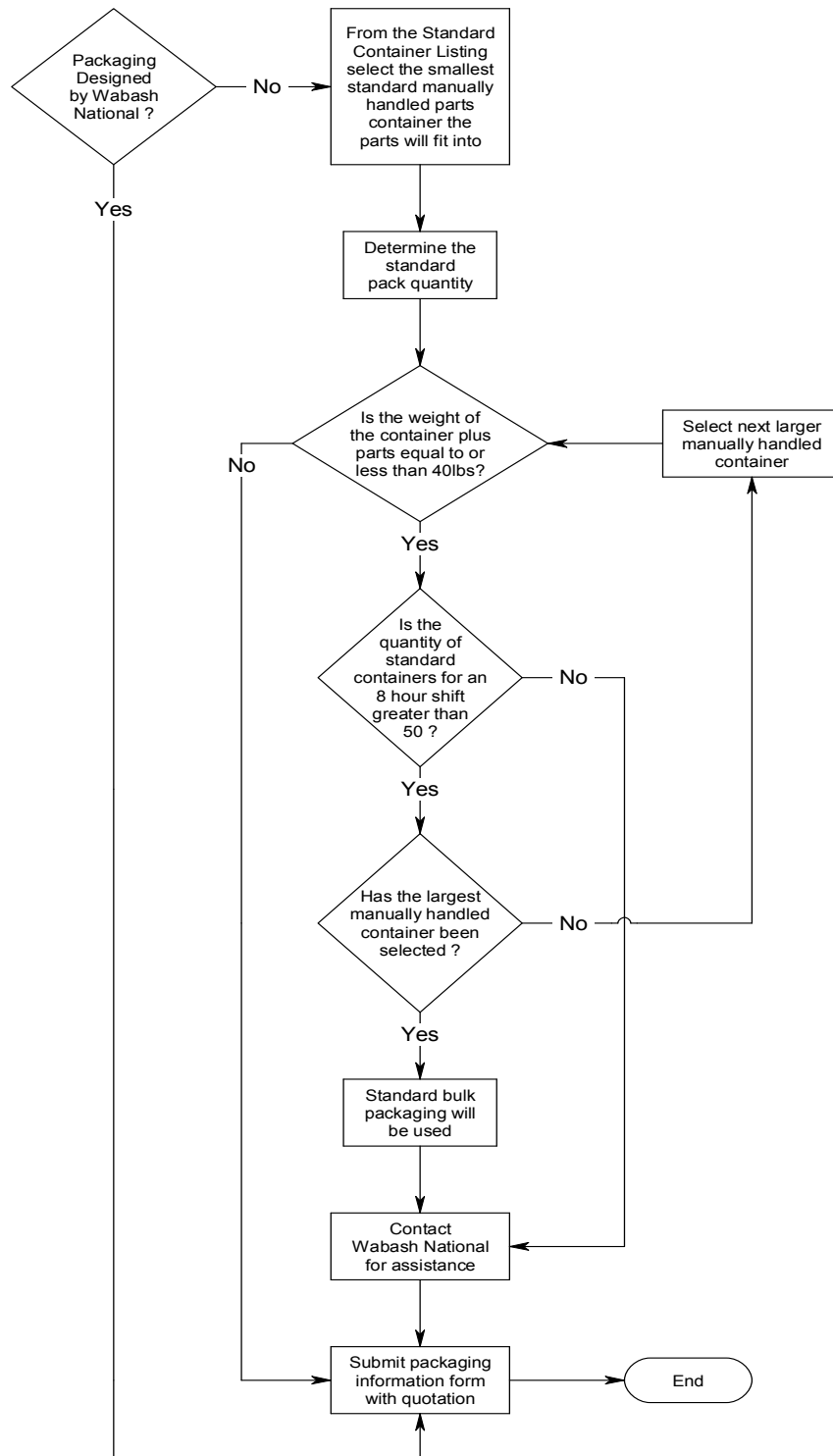

## 11 ERGONOMIC GUIDELINES

### 11.1 Container Size and Weight:

11.1.1 The weight of the containers must be specified in your quote package. If no weight limit is specified, the weight of any manually handled container cannot exceed 35 pounds (15.9 kilograms). Supermarket routes are assigned with the operator handling containers with a weighted average between 28 lbs. and 32 lbs. (12.7 – 14.5 kg).

11.1.2 Suggested container size limits are shown below.

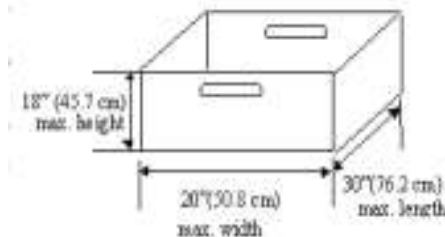

11.1.3 Handling over-sized containers - containers that exceed the above dimensions are most likely to exceed the 30 inch (76.2 cm.) length limit. Handling of over-sized containers should be acceptable if:

11.1.4 The weights are relatively light: 30 lb. (13.6 kg) or less

11.1.5 They are lifted/lowered to / from vertical heights under about 48 inches (121.9 cm.)

11.1.6 Two of the three dimensions are within the recommended size limits

11.1.7 Container has well-designed and well-located handholds.

11.1.8 The over-sized containers are a minority of containers handled (30 % or less).

## 12 SOME RECOMMENDED HANDHOLDS and DIMENSIONS:

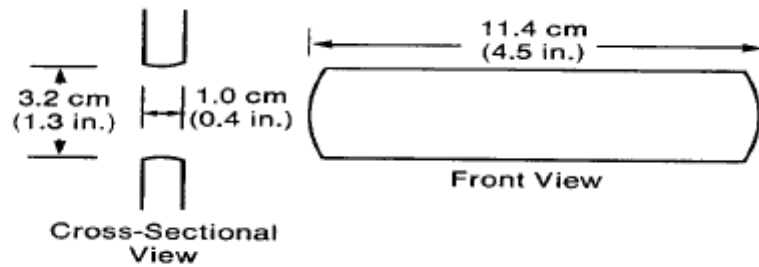

**(a) Handhold Cutout**

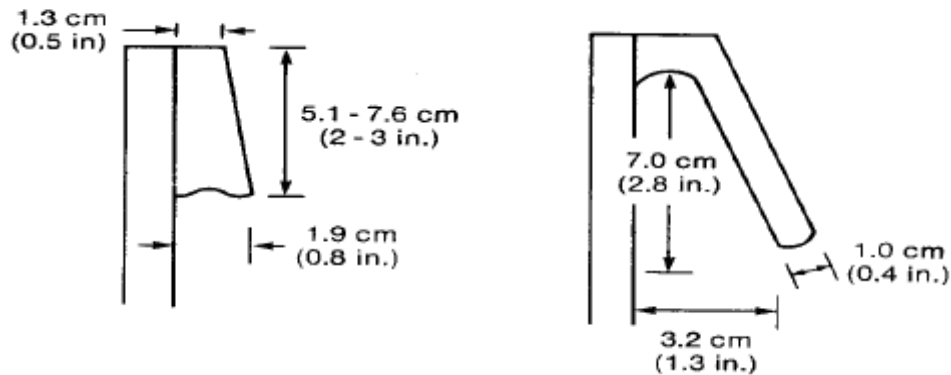

**(b) Gripping Block**

**(c) Drawer Pull**

## 13 TESTING AND VALIDATION

13.1 Package testing is the most efficient means of ensuring that the basic functions of containment and protection are provided to ensure the integrity and safety of contents.

- 13.1.1 Containment – To contain the product from point of manufacture to delivery at its point of use.
- 13.1.2 Protection – To protect the product from various hazards encountered in the distribution environment.
- 13.1.3 Performance – To perform in various ways for enabling packing, handling, storage, transportation, unpacking, disposal, etc.

## 13.2 Supplier Responsibilities

- 13.2.1 Ensure the part integrity during transportation, subsequent handling, and storage through point of use. The supplier should develop methods to test the pack design under simulated real-life conditions.
- 13.2.2 The approval by Wabash National of the packaging system does in no way relieve the suppliers of their responsibility for part integrity
- 13.2.3 Provide Wabash National with validation results and testing documentation.

## 14 HAZARDOUS MATERIALS

- 14.1 The supplier is responsible for assuring shipment of hazardous materials are in compliance with all government regulations or any other relevant international, federal, state, provincial or local requirement regulations.
- 14.2 The supplier is responsible for informing Wabash National of any packaging that contains materials that may render the packaging “hazardous” as defined by the laws of the country or countries where the packaging is to be used. This information should be in the form of a notification to the supplier’s purchasing contact that includes the Wabash National part number and the hazardous constituent of concern that is incorporated in the packaging. Approval for the transfer of ownership to the using plant of hazardous packaging will require the approval of the plant Environmental Health & Safety (EHS) personnel based on the availability of suitable, economical disposal.

- 14.3 The supplier is required to provide “Material Safety Data Sheets” to the shipping and receiving location’s Environmental Health & Safety (EHS) department.

## **15 RETURNABLE CONTAINER SYSTEMS**

A returnable has a design and function permitting it to be used more than once in a defined supplier-customer system. All returnable containers will include a cardholder and a label placard. The tare weight must be stamped into the individual components of the container system.

## **16 MAINTENANCE, REPAIR AND CLEANING**

### **16.1 Wabash National Responsibilities**

16.1.1 Wabash National, when shipping empty containers, will assure the containers are free of debris (some might contain internal dunnage)

16.1.2 The maintenance and repair procedures will be handled on an individual customer / supplier basis.

### **16.2 Supplier Responsibilities**

16.2.1 Clean returnable containers, including residue, and expendable dunnage, when required. Routine checks should be made and regular cleaning should occur as needed to ensure part quality and cleanliness during the life of the container.

16.2.2 Load production parts into clean undamaged containers only and load the skid into the transportation equipment in a manner that maintains part quality.

16.2.3 Contact Wabash National material handling personnel for repair if a damaged container or pallet is detected. Remove damaged unit immediately from the system.

16.2.4 Remove all one-time shipment labels on returnable packaging.

16.2.5 Suppliers shall store containers in a manner, which allows ease of inventories, maintains cleanliness, and protects containers from excessive environmental exposure.

## 17 RETURNABLE PACKAGING OWNERSHIP

### 17.1 Wabash National Responsibilities

- 17.1.1 Controls the ownership/handling of returnable container systems.
- 17.1.2 Maintenance, repair and cost of Wabash National owned systems
- 17.1.3 Coordinate any economic feasibility study to assure acceptable return on investment.
- 17.1.4 Provide recommended returnable system.
- 17.1.5 Approve system size and returnable system proposals.
- 17.1.6 Provide disposition of obsolete/damaged containers.
- 17.1.7 Provide instructions to container manufacturers on proper marking of the returnable containers and required documents in support of Customs special trade or tariff reduction programs.
- 17.1.8 Returnable containers must include the markings "Container made in (country)" and a unique identifier such as part number.

## 17.2 Supplier Responsibilities

- 17.2.1 Wabash National returnable containers are to be used only for shipment of Wabash National products and are to be maintained in good order. Under no circumstances will damaged packaging be used for shipments to Wabash National facilities.
- 17.2.2 Assure accurate container identification and quantities (including pallets, returnable dunnage and containers) are included in all ASN (Advance Shipping Notice).
- 17.2.3 Maintain continuous shipping and receipt records of all Wabash National owned returnable packaging including:
  - 17.2.3.1 Outbound shipments by container and location.
  - 17.2.3.2 Supplier in-plant reserve.
  - 17.2.3.3 Balance not returned from Wabash National.
  - 17.2.3.4 Inspect all containers upon return and document any damaged containers.

## 18 EXPENDABLE CONTAINER SYSTEMS

### 18.1 PALLET SIZE AND CONSTRUCTION

- 18.1.1 **Size:** Wabash National standard foot prints are governed by the size and cube of transporting conveyance.

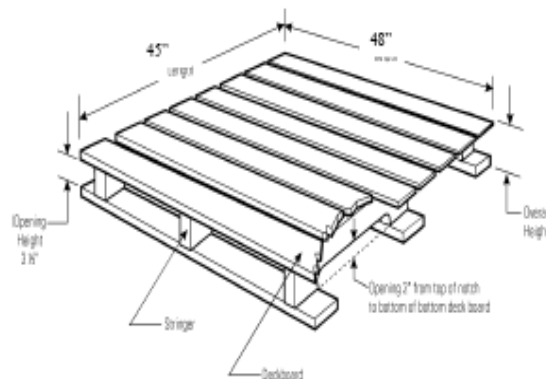

18.1.2 **North American Standards:** A 45" (1143 mm) x 48" (1219 mm) x 5" (127 mm) pallet has 45" (1143 mm) stringers, 48" (1219 mm) deck boards and the top of the deck is 5" (127 mm) above the floor. For the four –way entry pallet, the primary (easy entry) opening is across the 48" (1219 mm) width.

18.1.2.1 Non-reversible four-way entry stringer wood pallets, with 3.5" (88.9 mm) minimum primary opening height are required. Two-way entry may be used on 32" (812 mm) x 30" (762 mm) pallets.

18.1.3 **Metric Standards:** 1000 mm (39in) x 1200 mm (47 in) x 145 mm (6 in) pallet has 1000 mm (39 in) stringers, 1200 mm (47 in) deck boards and the top of the deck is 145 mm (6 in) above the floor. For the four –way entry pallet, the primary (easy entry) opening is across the 1200 mm (47in) width.

18.1.3.1 Non-reversible four-way entry stringer construction wood pallets, with 88.9 mm (3.5 in) minimum primary opening height are required. Two-way entry may be used on 800 mm (31 in) x 600 mm (24 in) pallets.

18.1.4 **Construction:** The pallet must have the minimum strength to withstand the static and dynamic forces foreseen for the distribution environment. Pallet design criteria must be incorporated to prevent pallet deformations, damages and structural failures that which detrimentally affect the functionality of the unit load. Refer to ASTM D1185 designation – Standard Test Methods for Pallets and Related Structures Employed in Materials Handling and Shipping – for testing details and pallet acceptance criteria. Additional requirements that will apply are as follows:

18.1.4.1 Nailed construction is required. Minimum 2 ¼" (57.15 mm) long, four-flute helical hardened nails are recommended.

18.1.4.2 Deck boards should be spaced close enough to provide adequate support to the product and prevent the product from falling through.

18.1.4.3 The pallet must have the strength to stack three high (when full) in storage or to a height of 10.5 feet (3.2004 m), whichever is greater.

18.1.4.4 Structural members of the pallet should be compatible with the carton by supporting the edge and corners.

18.1.4.5 Identification of manufacturer and / or pallet name printed on the pallet runner is required.

**Also refer to ASTM Standards for Pallet requirements: D6199-07, D442-07, D2395, D4444 and T208.**

18.2 **Corrugated pallets** are acceptable for use when the gross pallet weight is less than 500 pounds (226.8 kg). Wabash National must approve the type and style.

18.2.1 A solid corrugated deck is required.

18.2.2 If paper fiber cores are used for load-bearing members, use no more than four with a maximum thickness of ¼" (6.35 mm).

18.2.3 Recyclable pallet (100% corrugated) is required.

## 19 CONTAINER SIZE AND CONSTRUCTION

19.1 Containers are to be modular to the selected shipping pallet.

19.2 Containers must be palletized to permit handling with industrial trucks when sufficient part quantities are to be shipped.

19.3 Containers must be oriented to fully utilize the length and width of the pallet. To ensure vertical integrity, containers must not overhang the pallet. Brick stacking of containers is prohibited.



Brick stacking is prohibited.

- 19.4 The use of half slotted containers (HSC) is strongly recommended. One common cover over each full layer of cartons on a pallet is the preferred method; although in some cases individual lids may be required. The use of uncovered (uncapped) HSCs is not acceptable.
- 19.5 Mainstream for regular slotted container (RSC) is perforated tops, taped with the proper method. The proper method for taping is to tape the carton using a “doubled back” taping technique on one end of the carton. This technique forms a pull tab on the tape. The pull tab allows the operator to release the tape from the carton without the need for a sharp object to cut the tape.
- 19.6 To create the pull tab:
  - 19.6.1 Tape the carton on one end panel and over the center seam.
  - 19.6.2 Create the pull tab by extending the tape beyond the length of the carton approximately 6 inches.
  - 19.6.3 Seal the other end panel and double back the remaining portion of the tape on itself so that the two surfaces stick together to create the pull tab.
- 19.7 Corrugated material in shipping containers must have adequate strength to allow the parts to arrive at the using location in the same quality condition in which they were manufactured.
- 19.8 A minimum 44 ECT (edge crush test) or 275 pound burst test is required.
- 19.9 Packaging materials coated or impregnated with wax or plastics are not permissible.

- 19.10 All containers must be constructed with an outside tab style manufacturer's joint. A stitched manufacturer's joint is recommended and will be required if a glued or other type joint proves inadequate.
- 19.11 All containers must have a box maker's certificate visible on the assembled container displaying edge crush (ECT), bursting, or puncture test.
- 19.12 The use of scored drop sides on palletized cartons maybe required. Although normally on the longer side of the container, the location and size of the drop side is determined by part orientation and operator ergonomics. Consult Wabash National if further clarification is required.
- 19.13 Wire bound wood pallet boxes or wood and wood composite crates are not acceptable.
- 19.14 Expendable container systems based on paper products, paperboard, fiberboard or similar materials must be designed to withstand an environmental atmosphere of 40°C +/- 2°C (104°F +/- 4°F) with an 85% +/- 5% relative humidity. Suggested pre-condition environment considers a temperature of 23°C +/- 1.0°C (73°F +/- 2°F) with a 50% +/- 2% relative humidity. Refer to ASTM D685 designation – Standard Practice for Conditioning Paper and Paper Products for Testing – and ASTM D4332 designation – Standard Practice for Conditioning Containers, Packages or Packing Components for Testing – for additional details.
- 19.15 Any other expendable container system must be designed to withstand temperature variations from (-)29°C to (+)60°C [(-)20°F to (+)140°F] with relative humidity variations up to 85% +/- 5%. Refer to ASTM D4332 – Standard Practice for Conditioning Containers, Packages or Packaging Components for Testing – for details on environmental considerations.

## 20 CONTAINER CLOSURE

Closure refers to the method in which containers must be sealed, after being filled, for shipping and handling. Containers must be adequately sealed to assure they do not open during shipping or handling. Taping, gluing, or stapling is generally accepted for closure. Packaging materials containing asphalt, such as asphalt sealing tapes are prohibited. Environmentally, paper tape is preferred over plastic film tapes where sealing performance is not compromised.

## 21 CONTAINER SECUREMENT

21.1 All expendable containers shipped on pallets must be adequately secured to the pallets. Nailing, stapling, or gluing is not acceptable. The following are acceptable methods for securing cartons to a pallet:

21.1.1 **Unitizing Adhesives** – Use of a high shear / low tensile strength, quick release liquid. Unitizing adhesive is the best environmental option.

21.1.2 **Plastic (Non-Metallic) Strapping** – A minimum of two vertical bands lengthwise and two vertical bands widthwise must be used. Horizontal banding of corrugated boxes is prohibited. Polyester strapping is recommended because of its strength. Wabash National must approve use of any other strapping material.

21.1.2.1 Strapping color must be standardized. Polyester strapping must be translucent green and polypropylene strapping must be translucent clear.

21.1.2.2 Non-metallic strapping must be joined with a friction seal. Metal clips or buckles are approved

21.1.2.3 Metallic strapping is prohibited.

- 21.1.3 **Stretch film** – Stretch film **should be** bilinear low-density polyethylene (LLDPE) and clear in color to maximize recycling potential. PVC film is not permitted. A minimum 1” (25.4 mm) wing construction pallet is required for stretch wrapped packs. A minimum of three layers of stretch film are required around and encompassing the pallet. Stretch film must be fully secured to 3” (76.2 mm) below the deck boards of the pallet. Stretch film must have enough clarity to enable bar code scanning of labels.

## 22 SYSTEM PERFORMANCE CHARACTERISTICS

- 22.1 Maximum stacked load heights (containers plus pallet) must not exceed 96 in (1220 mm).
- 22.2 Maximum weight of any load (containers plus pallet) is 2000 pounds (907.18 kg).
- 22.3 Container designs must provide for dynamic (in transit) loading of three times the static (in storage) load. Suitable non-stapled corner supports and top stacking frames may be necessary to meet this requirement.
- 22.4 Air freight shipments, LTL (less than truckload), and other special shipments are subject to abnormal handling and require more substantial packaging.

## 23 EXPORT / IMPORT REQUIREMENTS

Below are the general guidelines to be followed when shipping parts from one country to another country:

- 23.1 Supplier will monitor governmental & automotive industry regulations for changes related to packaging & shipping information.
- 23.2 When shipping by airfreight, special reinforced packaging may be necessary.
- 23.3 Packaging materials shall protect part quality for a minimum of 30 days for Intra-continent shipments and minimum of 90 days for Inter-continent shipments.
- 23.4 Suppliers must comply with international phytosanitary guidelines regarding non-manufactured wood products [NMWP], when shipping parts from one country to another country. These requirements provide guidance on the treatment and marking of coniferous and non-coniferous wooden packaging products. For information regarding the international guidelines, go to the International Phytosanitary Portal [IPP] at <http://www.ippc.int/IPP>

## 24 INTERNAL DUNNAGE

Internal dunnage is considered to be a packaging component that requires a pallet or container to be shippable (e.g. vacuum formed or thermoformed trays are internal dunnage to a pallet). Dunnage can be used in both returnable and/or expendable systems. Dunnage shall be used when part-to-part contact must be eliminated to prevent damage in shipping and handling or in cases where special part orientation as provided in your quote package is requested. Suppliers are responsible for the design, performance, and procurement of all expendable dunnage. Container loading, unloading, and waste recycling / disposal must be considered when designing interior dunnage. The use of dunnage constructed of combined and / or non-recyclable materials is prohibited.

## 25 SHIPPING LABELS

Below are the general guidelines to be followed when placing labels on all containers: Supplier is responsible to ensure correct labeling is provided for all packaging. Wabash National recommends using the automobile AIAG standard.

- 25.1 Hand written or stenciled label information is prohibited.
- 25.2 If placards are or available on containers, use this area to apply shipping labels.
- 25.3 Any deviations must be reviewed and approved by Wabash National.
- 25.4 Pull card holders for both expendable and returnable containers are required.
- 25.5 Where container size does not adequately provide for the use of standard shipping labels, contact Wabash National

## 26 MIXED LOADS

A mixed load occurs when more than one part number is shipped on a pallet. (Note: Loads should never be mixed in a bulk container system.) A mixed load should be considered mainstream when frequency of delivery requires less than full pallet loads. This also allows better cube utilization of the transportation system. When shipping a mixed load the following requirements must be met: A mixed load label must be affixed to the load on all four corners along side where the shipping label is normally attached. In addition, a mixed load manifest or packing slip must be attached to the load that indicates the part numbers shipped and how many containers are associated with each part number.

- 26.1 The packaging slip will designate the entire contents of the load.
- 26.2 Similar part numbers will be grouped together on the pallet for ease of identification and accountability.
- 26.3 The containers must be positioned on the pallet so the label faces the outside perimeter of the pallet for ease of identification. When possible, all labels should be visible to ease identification and accountability requirements.
- 26.4 Partial loads should be shipped with the void in the center of the pallet.
- 26.5 Care should be taken to balance the load by distributing the weight as evenly as possible, remembering that similar products must be grouped.
- 26.6 The load may require special attention to secure the containers if void and or irregular configuration occurs. Stretch wrap is the preferred method.
- 26.7 Level layers are mainstream, but if the mixed load makes this impossible, the following additional requirements are mandatory.
  - 26.7.1 Cross stacking returnable containers to be used when possible.
  - 26.7.2 Ship the load without a pallet or top cap on the top of the load.
  - 26.7.3 "Do Not Stack" label is required on all 4 sides of the load.
  - 26.7.4 Special attention is required to secure the top of the load since a top pallet or top cap can't be used.
  - 26.7.5 Do not mix bulk and hand carry containers on the same pallet.

## 27 PACKAGING EXAMPLES



Manually Handled Returnable

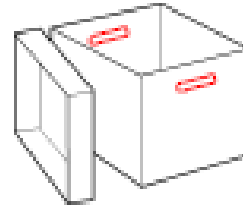

Manually Handled Expendable  
**Or 3” flaps**



Bulk Returnable



Bulk Expendable



Palletized Load Returnable

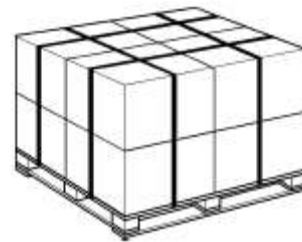

Palletized Load Expendable

## 28 RECYCLING INFORMATION



### SPI PLASTIC RESIN CODES

To facilitate the recycling of a product, its identity must be known. There are numerous types of plastics used for automotive packaging which require a simple method of identification. Wabash National will require the SPI (Society of Plastics Industry) coding; the same as on retail packaging. The SPI code chart is shown below. All vacuum-formed and injection-molded plastic packaging material must be identified by this code.

**NOTE:** Plastic components that are assembled to the vehicle are to be identified with the proper SAE code to facilitate recycling. Packaging material must be marked with the appropriate SPI code.

| KEY     | SPI CODES  | KEY    | SPI CODES                 |
|---------|--|--------|---------------------------|
|         |  |        |                           |
| 1-PET   | Polyethylene Terephthalate                             | 2-HDPE | High-Density Polyethylene |
|         |  |        |                           |
| 3-V     | Vinyl/Polyvinyl Chloride                               | 4-LDPE | Low-Density Polyethylene  |
|         |  |        |                           |
| 5-PP    | Polypropylene  | 6-PS   | Polystyrene               |
|         |  |        |                           |
| 7-Other | All Other Resins and Layered Multi-Material MDPE-PE/PP |        |                           |

## 29 WASTEFUL, EXCESSIVE, OR NON-RECYCLABLE MATERIAL



Packaging is required to serve many needs; part protection, transportation effectiveness, synchronous manufacturing and ergonomic and environmental concerns to name a few. Proposed and impending state and federal legislation is prohibiting wasteful and/or excessive packaging. The challenge is to meet these requirements with the amount and degree of packaging necessary and no more. Over-packaging and wasteful “just-in-case” packaging is undesirable for both the supplier and the user. Each Wabash National supplier is expected to identify and correct such packaging on an on going basis.

With reduction or elimination as the first priority  
The hierarchy of waste elimination is:

REDUCE -----> REUSE -----> RECYCLE

To list every example of wasteful, excessive or non-recyclable packaging would be too extensive. We have identified a few examples that have been significant problems at the plants.

- Cartons partially filled.
- Oversized foam, plastic or corrugated dunnage.
- Micro cellular foam wrap and bubble wrap.
- Plastic protective covers, caps, plugs, paint masks or spacers required in the manufacturing process, but not required as a protective shipping device.
- Corrugated carton test strength that far exceeds requirements.

Non-recyclable packaging is that which has no available or economical system in place to process an item. Wax-coated corrugated cardboard is a prime example of this type of packaging. Waxed or plastic coated paper is prohibited, unless otherwise directed by Wabash National Non-Kraft corrugated has no recycle value and, therefore, is unacceptable by Wabash National and also the recycling centers. Plastic plugs, caps, and protectors are extremely difficult to recycle due to oil and paint contamination, colors, uncertainty of resin type, and transportation costs. Every effort should be made to eliminate the plastic. If it cannot be eliminated, other changes can be made to assist the recycling efforts.

- Mold the Society of Plastics Code (#1-7) into the part. When elimination is not possible, these codes will allow for effective recycling.
- Clear LDPE plastics are preferred and can be effectively recycled.
- Ship plastics uncontaminated with paints and lubricants.
- Replace the plastic with a paper substitute.

Any plastic cap, plug, spacer, etc., if not required for packaging or shipping protection, must be removed prior to shipment to the assembly plant.

### **30 FORMS AND SUPPLEMENT GUIDELINES**

- 30.1 **Attachment A1:** Standard Container Listing: North American Standards
- 30.2 **Attachment A2:** Standard Container Listing: European & Metric Standards
- 30.3 **Attachment B:** Wabash National Packaging Checklist Form

### **ADDITIONAL REFERENCES**

(Available at most libraries and bookstores):

ASTM (American Society for Testing and Materials)  
ISTA (International Safe Transit Association)

## Attachment A1 – Standard Container Listing:

### North American Standards

#### Manually Handled Containers

| IN   | MM              | Pallet Size | Containers per layer | Maximum # of containers on Sec Ctnr | Tare Wt | Material | Nomenclature   |
|--|-----------------|-------------|----------------------|-------------------------------------|---------|----------|----------------|
| <b>Standard parts are to be packed in one of the 2 options shown below</b> |                 |             |                      |                                     |         |          |                |
| 9 x 9 x 4  | 29 x 229 x 102  | 45 x 48     | 25                   | 10                                  |         |          | EXPENDABLE CTN |
| 9 x 9 x 6  | 29 x 229 x 153  | 45 x 48     | 25                   | 7                                   |         |          | EXPENDABLE CTN |
| <b>North American Standards</b>  |                 |             |                      |                                     |         |          |                |
| 12 x 7½ x 4  | 305 x 191 x 102 | 45 x 48     | 24                   | 10                                  | 1.1lb   | HDPE     | D120804 (XL)*  |
| 12 x 15 x 4  | 305 x 381 x 102 | 45 x 48     | 12                   | 10                                  | 2.0lb   | HDPE     | D121504(X)     |
| 12 x 15 x 7½   | 305 x 381 x 191 | 45 x 48     | 12                   | 5                                   | 2.7lb   | HDPE     | D121508(X)     |
| 24 x 15 x 4  | 610 x 381 x 102 | 45 x 48     | 6                    | 10                                  | 3.0lb   | HDPE     | D241504(X)     |
| 24 x 15 x 7  | 610 x 381 x 191 | 45 x 48     | 6                    | 5                                   | 4.6lb   | HDPE     | D241508(X)     |
| 24 x 15 x 11   | 610 x 381 x 280 | 45 x 48     | 6                    | 3                                   | 5.0lb   | HDPE     | D241511(X)     |
| 24 x 15 x 14½  | 610 x 381 x 369 | 45 x 48     | 6                    | 2                                   | 8.3lb   | HDPE     | D241515(X)     |
| 24 x 22½ x 7½  | 610 x 572 x 364 | 45 x 48     | 4                    | 5                                   | 6.9lb   | HDPE     | D242308(X)     |
| 24 x 22½ x 11  | 610 x 572 x 280 | 45 x 48     | 4                    | 3                                   | 7.3lb   | HDPE     | D242311(X)     |
| 24 x 22½ x 14½   | 610 x 572 x 369 | 45 x 48     | 4                    | 2                                   | 1.3lb   | HDPE     | D242315(X)     |

#### Preferred Pallet Size

| IN                              | MM          |
|---------------------------------|-------------|
| <b>North American Standards</b> |             |
| 45 x 48                         | 1143 x 1219 |

#### Sizes of Bulk Containers

| IN                              | MM                |
|---------------------------------|-------------------|
| <b>North American Standards</b> |                   |
| 32 x 30 x 25                    | 813 x 762 x 635   |
| 32 x 30 x 34                    | 813 x 762 x 864   |
| 48 x 45 x 25                    | 1219 x 1143 x 635 |
| 48 x 45 x 34                    | 1219 x 1143 x 864 |

#### Acceptable Pallet Sizes

| IN                              | MM        |
|---------------------------------|-----------|
| <b>North American Standards</b> |           |
| 32 x 36                         | 813 x 914 |

**Notes:** This listing provides right sized standards for expendable as well as returnable containers. The dimensions shown should be considered outside measurements for both packaging options.

**Legend:** (X) : Cross stack container  
 (XL) : Cross stack container with a hinged lid  
 \* Currently is manufactured as a cut and weld container

# Attachment A2 – Standard Container Listing:

## European & Metric Standards

### Manually Handled Containers

| Expendable Carton MM | Returnable Container MM | Pallet Size | Containers per Layer |
|----------------------|-------------------------|-------------|----------------------|
|                      | 200 x 150 x 140         | 600 x 800   |                      |
| 300 x 200 x 150      | 297x 198 x 148 VDA      | 1200 x 1000 | 20                   |
| 300 x 200 x 150      | 300 x 200 x 114 Gallia  | 1200 x 1000 | 20                   |
| 300 x 200 x 200      | 300 x 200 x 214 Gallia  | 1200 x 1000 | 20                   |
| 400 x 300 x 150      | 396 x 297 x 148 VDA     | 1200 x 1000 | 10                   |
| 400 x 300 x 150      | 400 x 300 x 114 Gallia  | 1200 x 1000 | 10                   |
| 400 x 300 x 200      | 396 x 297 x 280 VDA     | 1200 x 1000 | 10                   |
| 400 x 300 x 200      | 400 x 300 x 214 Gallia  | 1200 x 1000 | 10                   |
| 600 x 400 x 200      | 594 x 396 x 280 VDA     | 1200 x 1000 | 5                    |
| 600 x 400 x 200      | 600 x 40 x 214 Gallia   | 1200 x 1000 | 5                    |
| 600 x 400 x 300      | 600 x 40 x 314 Gallia   | 1200 x 1000 | 5                    |

### Preferred Pallet Sizes

| IN               | MM          |
|------------------|-------------|
| Metric Standards |             |
| 47.2 x 31.4      | 1200 x 800  |
| 47.2 x 39.3      | 1200 x 1000 |

### Bulk Containers

| IN                 | MM                |
|--------------------|-------------------|
| Metric Standards   |                   |
| 31.5 x 23.6 x 18.3 | 800 x 600 x 465   |
| 47.2 x 39.3 x 33.9 | 1200 x 1000 x 860 |
| 47.2 x 39.3 x 38.4 | 1200 x 1000 x 975 |

### Acceptable Pallet Sizes

| IN               | MM         |
|------------------|------------|
| Metric Standards |            |
| 23.6 x 31.4      | 600 x 800  |
| 23.6 x 39.3      | 600 x 1000 |

**Notes:** This listing provides right sized standards for expendable as well as returnable containers. The dimensions shown should be considered outside dimensions for both packaging options.



# GLOSSARY OF TERMS

**Adhesive** - A material capable of attaching one surface to another. As used in connection with fiber boxes; a material to glue plies of solid fiberboard, to glue facings to corrugating medium in combined corrugated board, to glue the overlapping sides of a box forming the manufacturer's joint or to glue the flaps in closing a slotted box.

**Box (Carton)** - A rigid container having closed faces and completely enclosing its contents.

**Box Maker** - A corrugated or solid fiber box manufacturing establishment which has equipment to score, slot, print and joins corrugated or solid fiber sheets into boxes, which equipment is regularly utilized in the production of fiber boxes in commercial quantities.

**Brick Stacking** - The act of alternating the stacking of containers on pallets, length by width and width by length.

**Bursting Strength** - The strength of material expressed in pounds per square inch.

**Closure** - The method used to seal a container once the parts have been packaged within it.

**Containerization** - Packaging parts in the smallest lot possible resulting in presentation of a quality part to eliminate waste of motion for the manufacturing operator. Note: The best container for the operator is no container.

**Containment** - To contain the product from point of manufacture until delivery at its point of use.

**Cross Stack** – A feature molded into the bottom of returnable manually handled container that allows a larger container to stack on top a number of smaller containers.

**Deck** - The horizontal load-carrying or load-bearing surface of a pallet.

**Deck Opening** - Any void in the deck caused by the spacing of surface elements or a cutout in a solid deck pallet.

**Deck board** - The surface element used in the construction of a pallet deck.

**Distribution Environment** – The entire material flow process from supplier through user.

**Duns Number** - A number designation code assigned to shippers by Dun & Bradstreet.

**Dunnage** - Devices or materials used to hold, secure, or protect goods during shipment.

**Expendable** – A pack that makes only one trip.

**Footprint** - The outermost dimensions (length and width) of a pallet, container or container system.

**Four-way Pallet** - A pallet constructed to allow insertion and withdrawal of handling equipment from all sides of the pallet.

**Height** - The overall dimension of the container in the vertical direction. In the case of cartons on a pallet, it is the dimension from the bottom of the pallet to the top of the highest carton.

**Half Slotted Container** - Same as Regular Slotted Container without one set of flaps (a box which requires a separate lid).

**Joint** - That part of the box where the ends of the scored and slotted blank are jointed together by taping, stitching, or gluing. When accomplished in the box manufacturer's plant, it is known as a manufacturer's joint; when effected at the time the box flaps are sealed in a box user's plant (usually on automatic equipment), it is called a user's joint.

**Overhang** - That portion of the unit load that exceeds the width or length dimension of a pallet. (Not allowable).

**Pack Validation** - The process used to test the basic functions of containment and protection.

**Pad** - A corrugated or solid fiberboard sheet or other authorized material used for extra protection or for separating tiers or layers of articles when packed for shipment.

**Pallet** - A horizontal platform device used as a base for assembling, storing, handling, and transporting materials and products in a unit load.

**Pallet Length** - The dimension parallel to the stringers or stringer boards of a pallet size.

**Pallet Width** - The dimension parallel to the top deck boards of a pallet.

**Performance** - To perform in various ways for enabling packing, handling, storage, transportation, unpacking, disposal, etc.

**Placard** - An easy release label or card holder area affixed to a container for the purpose of placing a label or Kan ban card.

**PPAP** - Production Part Approval Process.

**Primary Container** - The shippable container closest to the parts.

**Protection** - To protect the product from various hazards encountered in the distribution environment.

**PR/R** - Problem Reporting and Resolution.

**Returnable** – A pack that makes multiple trips.

**Rightsizing** - Containerization that optimizes the entire material flow process from supplier to user.

**Regular Slotted Container** - A corrugated box where all flaps have the same length, and the two outer flaps (normally the lengthwise flaps) are one-half the container's width, so that they meet at the center of the box when folded.

**Score** - An impression or crease in corrugated or solid fiberboard to locate and facilitate folding. (See also Slit-Score.)

**Seam** - The junction created by any free edge of a container flap or wall where it abuts or rests on another portion of the container and to which it may be fastened by tape, stitches or adhesives in the process of closing the container.

**Secondary Container** - A larger container on which multiple primary containers of a part are shipped.

**Standard Pack** - The Primary Container.

**Standard Pack Quantity** - The number of pieces in a shippable primary container.

**Stitching or Stapling** - Application of metal fasteners to form the joint of fiber boxes or to close boxes. Stitches are machine-formed using wire drawn from a spool. Staples are performed.

**Stringer** - A continuous longitudinal board member of a pallet that supports the horizontal load - carrying or load-bearing surface.

**Tape** - A strip of cloth or paper, sometimes having a filler or reinforcement, coated on one side with an adhesive. It is used to form the joint on a fiber box or to close or reinforce such a box. Closure and reinforcement can also be affected with pressure-sensitive tape.

**Tare Weight** - The weight of the container(s), excluding the weight of the parts.

**Test** - Bursting Strength (Mullen) - Measurement of the resistance of a material to bursting expressed in pounds per square inch. The test is made on a motor-driven Mullen tester.

## WABASH / SUPPLIER CHECKLIST

- Supplier has received a copy of the "Packaging Manual / Packaging Guidelines for Production Parts"
- Supplier understands the 4 primary goals for packaging parts found on page 1
- Supplier understands responsibilities from both Wabash National and his / hers individual company
- Supplier understands the "Decision Process for Container Rightsizing" found on page 5
- Supplier understands "Ergonomic Guidelines" found on page 6
- Supplier has reviewed the "Testing Guidelines" found on page 7
- Supplier has reviewed the "HAZARDOUS MATERIALS" section found on page 8
- Supplier has reviewed the "RETURNABLE CONTAINER SYSTEMS" found on page 9
- Supplier has provided Wabash National with a proposed packaging solution
- Supplier has visited the areas of Wabash National where these supplied parts will be used
- Supplier has visited the areas of Wabash National where these parts will be off loaded
- Supplier has visited the areas of Wabash National where these parts will be stored
- Supplier has given Wabash National a sample package with parts included for visual inspection